

DATA SHEET

PCK2021

CK00 (100/133 MHz) spread spectrum
differential system clock generator

Preliminary data

2001 Jul 24

CK00 (100/133 MHz) spread spectrum differential system clock generator

PCK2021

FEATURES

- 3.3 V operation
- Six differential CPU clock pairs
- Two PCI clocks at 33 MHz and one 3V66 clock
- Two 48 MHz clocks at 3.3 V
- One 14.318 MHz reference clock
- Power management control pins
- Host clock jitter less than 200 ps cycle-to-cycle
- Host clock skew less than 150 ps pin-to-pin
- Spread Spectrum capability
- Optimized frequency and spread spectrum performance

DESCRIPTION

The PCK2021 is a clock synthesizer/driver for a Pentium III™ and other similar processors.

The PCK2021 has six differential pair CPU current source outputs, two 33 MHz outputs, one 3V66 output, and two 48 MHz clocks which can be disabled on power-up, and one 3.3 V reference clock at 14.318 MHz which can also be disabled on power-up. All clock outputs meet Intel's drive strength, rise/fall times, jitter, accuracy, and skew requirements.

The part possesses a dedicated power-down input pin for power management control. This input is synchronized on chip, and ensures glitch-free output transitions. In addition, the part can be configured to disable the 48 MHz outputs for lower power operation and an increase in the performance of the functioning outputs. The REF and PCI outputs can also be disabled for the highest performance of the Host outputs.

PIN CONFIGURATION

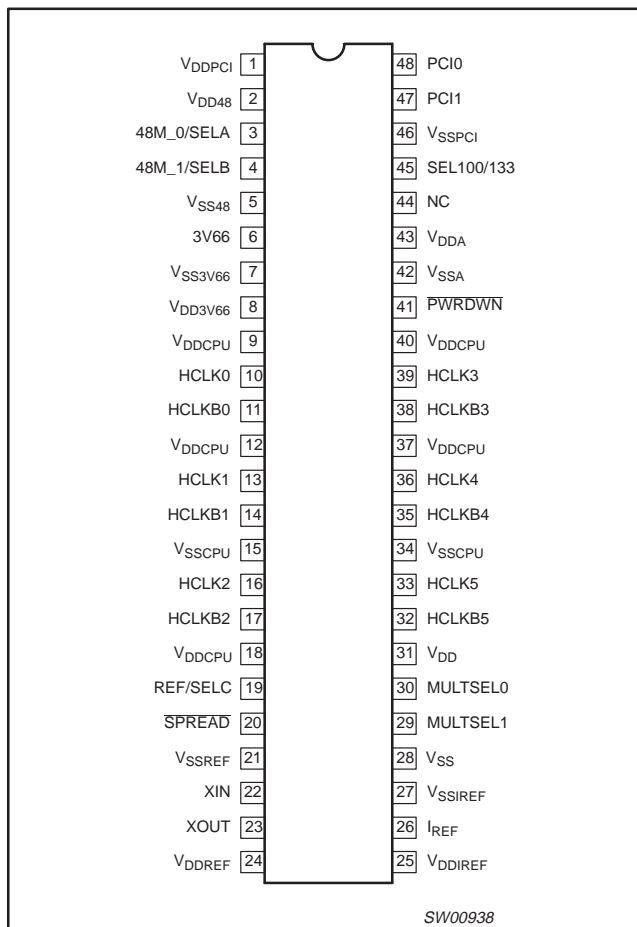

ORDERING INFORMATION

PACKAGES	TEMPERATURE RANGE	ORDER CODE	DRAWING NUMBER
48-Pin Plastic TSSOP	0 to +70 °C	PCK2021DGG	SOT362-1
48-Pin Plastic SSOP	0 to +70 °C	PCK2021DL	SOT370-1

Intel and Pentium III are trademarks of Intel Corporation.

CK00 (100/133 MHz) spread spectrum differential system clock generator

PCK2021

PIN DESCRIPTION

PIN(S)	SYMBOL	FUNCTION
1, 2, 8, 9, 12, 18, 24, 25, 31, 37, 40	V _{DD}	3.3 V power supply Pins 9, 12, and 18 supply host output pairs 0, 1, and 2. Pins 37 and 40 supply host output pairs 3, 4, and 5.
3, 4	48M_0/SELA 48M_1/SELB	3.3 V fixed 48 MHz clock outputs. During power-up pins function as latched inputs that enable SELA and SELB prior to the pins being used for output of 3 V at 48 MHz. Part must be clocked to latch data in.
6	3V66	66 MHz clock: 66 MHz reference clock, 2/3 frequency of host clock
10, 11	HCLK0 HCLKB0	Host output pair 0
13, 14	HCLK1 HCLKB1	Host output pair 1
16, 17	HCLK2 HCLKB2	Host output pair 2
47, 48	PCI0 PCI1	33 MHz clocks: 33 MHz reference clocks, host clock divided by 3
39, 38	HCLK3 HCLKB3	Host output pair 3
36, 35	HCLK4 HCLKB4	Host output pair 4
33, 32	HCLK5 HCLKB5	Host output pair 5
19	REF/SELC	3.3 V fixed 14.318 MHz output. During power-up, pin functions as latched input for SELC. Part must be clocked to latch.
20	SPREAD	Enables spread spectrum mode when held LOW on differential host outputs, 3V66 and PCI clocks. Asserts LOW.
22	XIN	Crystal input
23	XOUT	Crystal output
26	I _{REF}	This pin controls the reference current for the host pairs. This pin requires a fixed precision resistor tied to ground in order to establish the correct current.
29, 30	MULTSEL0 MULTSEL1	Select input pin used to control the scaling of the HCLK and HCLKB output current.
41	PWRDWN	Device enters power-down mode when held LOW. Asserts LOW.
45	SEL100/133	Select input pin for enabling 133 MHz or 100 MHz CPU outputs
5, 7, 15, 21, 27, 28, 34, 46	V _{SS}	Ground
43	V _{DDA}	3.3 V power supply for analog circuits
42	V _{SSA}	Ground for analog circuits

CK00 (100/133 MHz) spread spectrum differential system clock generator

PCK2021

BLOCK DIAGRAM

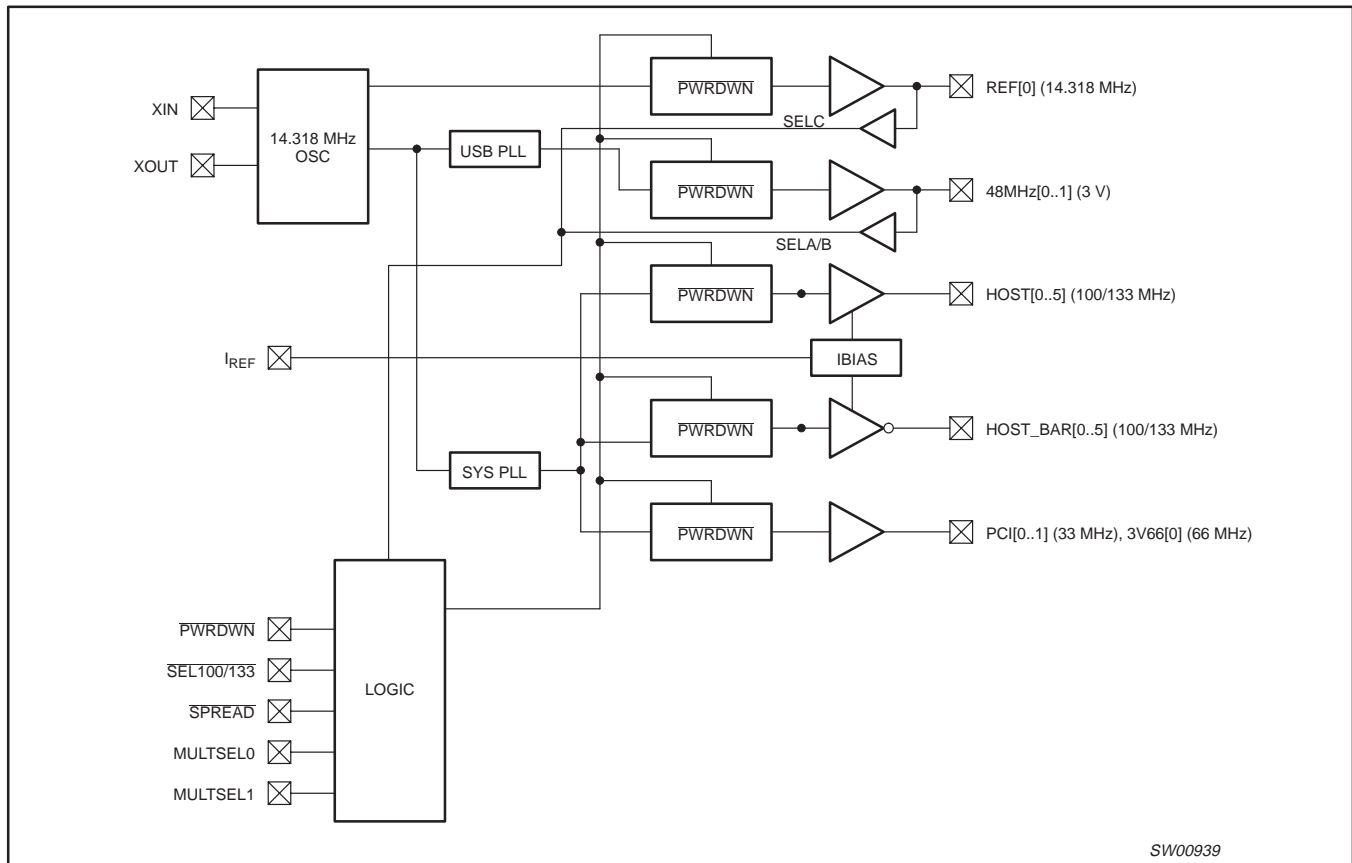

SW00939

FUNCTION TABLE

SEL100/133	SELA	SELB	SELC ¹	HOST	48MHz	PCI33MHz	66MHz	REFCLK
0	0	0	0	100 MHz	48 MHz	33.3 MHz	66.7 MHz	14.3 MHz
0	0	1	0	100 MHz	Disable/Low	33.3 MHz	66.7 MHz	14.3 MHz
0	1	0	0	100 MHz	Disable/Low	Disable/Low	66.7 MHz	Disable/Low
0	1	1	0	Hi-Z	Hi-Z	Hi-Z	Hi-Z	Hi-Z
1	0	0	0	133 MHz	48 MHz	33.3 MHz	66.7 MHz	14.3 MHz
1	0	1	0	133 MHz	Disable/Low	33.3 MHz	66.7 MHz	14.3 MHz
1	1	0	0	200 MHz	48 MHz	33.3 MHz	66.7 MHz	14.3 MHz
0	0	0	1	100 MHz	48 MHz	66.7 MHz	66.7 MHz	14.3 MHz
0	0	1	1	100 MHz	Hi-Z	66.7 MHz	66.7 MHz	14.3 MHz
0	1	0	1	100 MHz	48 MHz	33.3 MHz	66.7 MHz	14.3 MHz
0	1	1	1	100 MHz	48 MHz	66.7 MHz	66.7 MHz	14.3 MHz
1	0	0	1	133 MHz	48 MHz	66.7 MHz	66.7 MHz	14.3 MHz
1	0	1	1	133 MHz	Hi-Z	66.7 MHz	66.7 MHz	14.3 MHz
1	1	0	1	133 MHz	48 MHz	33.3 MHz	66.7 MHz	14.3 MHz
1	1	1	1	133 MHz	48 MHz	66.7 MHz	66.7 MHz	14.3 MHz

NOTE:

1. Pin 19, REF/SECLC has an internal 50 kΩ pull-down resistor.

CK00 (100/133 MHz) spread spectrum differential system clock generator

PCK2021

Table 1. Host swing select functions

MULTSELO	MULTSEL1	BOARD IMPEDANCE	I _{REF}	I _{OH}	V _{OH} @ I _{REF} = 2.32 mA
0	0	60 Ω	R _{REF} = 475 1% I _{REF} = 2.32 mA	I _{OH} = 5*I _{REF}	0.71 V
0	0	50 Ω	R _{REF} = 475 1% I _{REF} = 2.32 mA	I _{OH} = 5*I _{REF}	0.59 V
0	1	60 Ω	R _{REF} = 475 1% I _{REF} = 2.32 mA	I _{OH} = 6*I _{REF}	0.85 V
0	1	50 Ω	R _{REF} = 475 1% I _{REF} = 2.32 mA	I _{OH} = 6*I _{REF}	0.71 V
1	0	60 Ω	R _{REF} = 475 1% I _{REF} = 2.32 mA	I _{OH} = 4*I _{REF}	0.56 V
1	0	50 Ω	R _{REF} = 475 1% I _{REF} = 2.32 mA	I _{OH} = 4*I _{REF}	0.47 V
1	1	60 Ω	R _{REF} = 475 1% I _{REF} = 2.32 mA	I _{OH} = 7*I _{REF}	0.99 V
1	1	50 Ω	R _{REF} = 475 1% I _{REF} = 2.32 mA	I _{OH} = 7*I _{REF}	0.82 V
0	0	30 Ω	R _{REF} = 221 1% I _{REF} = 5 mA	I _{OH} = 5*I _{REF}	0.75 V
0	0	25 Ω	R _{REF} = 221 1% I _{REF} = 5 mA	I _{OH} = 5*I _{REF}	0.62 V
0	1	30 Ω	R _{REF} = 221 1% I _{REF} = 5 mA	I _{OH} = 6*I _{REF}	0.90 V
0	1	25 Ω	R _{REF} = 221 1% I _{REF} = 5 mA	I _{OH} = 6*I _{REF}	0.75 V
1	0	30 Ω	R _{REF} = 221 1% I _{REF} = 5 mA	I _{OH} = 4*I _{REF}	0.60 V
1	0	25 Ω	R _{REF} = 221 1% I _{REF} = 5 mA	I _{OH} = 4*I _{REF}	0.50 V
1	1	30 Ω	R _{REF} = 221 1% I _{REF} = 5 mA	I _{OH} = 7*I _{REF}	1.05 V
1	1	25 Ω	R _{REF} = 221 1% I _{REF} = 5 mA	I _{OH} = 7*I _{REF}	0.84 V

NOTE:
The outputs are optimized for the configurations shown shaded.

	CONDITIONS	CONFIGURATION	LOAD	MIN.	MAX.
I _{OUT}	V _{DD} = 3.3 V	All combinations; see Table 1 above	Nominal test load for given configuration	-7% of I _{OH} see Table 1 above	+7% of I _{OH} see Table 1 above
I _{OUT}	V _{DD} = 3.3 V ±5%	All combinations; see Table 1 above	Nominal test load for given configuration	-12% of I _{OH} see Table 1 above	+12% of I _{OH} see Table 1 above

POWER-DOWN MODE

PWRDWN	HCLK/HCLKB	3V66	PCI	48MHz	REFCLK
Asserts LOW 0 = Active	Host = 2*I _{REF} Host_bar = undriven	LOW	LOW	LOW	LOW

NOTE:
The differential outputs should have a voltage forced across them when power-down is asserted.

SPREAD SPECTRUM FUNCTION

SPREAD #	FUNCTION	48 MHz PLL REFCLK
1	Host, PCI, and 3V66 No Spread	No Spread
0	Host, PCI, and 3V66 Down spread -0.5%	No Spread

CK00 (100/133 MHz) spread spectrum differential system clock generator

PCK2021

ABSOLUTE MAXIMUM RATINGS

SYMBOL	PARAMETER	CONDITIONS	LIMITS		UNIT
			MIN	MAX	
V_{DD3}	DC 3.3 V supply		-0.5	4.6	V
I_{IK}	DC input diode current	$V_I < 0$	—	-50	mA
V_I	DC input voltage	Note 2	-0.5	V_{DD}	V
I_{OK}	DC output diode current	$V_O > V_{DD}$ or $V_O < 0$	—	±50	mA
V_O	DC output voltage	Note 2	-0.5	$V_{DD}+0.5$	V
I_O	DC output source or sink current	$V_O = 0$ to V_{DD}	—	±50	mA
T_{stg}	Storage temperature range		-65	+150	°C
P_{tot}	Power dissipation per package plastic medium-shrink (TSSOP)	For temperature range -40°C to +125°C; above +55°C derate linearly with 11.3 mW/K	—	850	mW

NOTES:

- Stresses beyond those listed may cause permanent damage to the device. These are stress ratings only and functional operation of the device at these or any other condition beyond those indicated under "recommended operating condition" is not implied. Exposure to absolute-maximum-rated conditions for extended periods may affect device reliability.
- The input and output voltage rating may be exceeded if the input and output current ratings are observed.

RECOMMENDED OPERATING CONDITIONS

SYMBOL	PARAMETER	CONDITIONS	LIMITS		UNIT
			MIN	MAX	
V_{DD3}	DC 3.3 V supply voltage		3.135	3.465	V
AV_{DD}	DC 3.3 V analog supply voltage		3.135	3.465	V
C_L	Capacitive load on:				
	3V666	1 device load, possible 2	10	30	pF
	PCI	Must meet JEDEC PCI 2.1 Spec. Requirements	10	30	pF
	48 MHz clock	1 device load	10	20	pF
	REF	1 device load	10	20	pF
f_{ref}	Reference frequency, oscillator normal value		14.31818	14.31818	MHz
T_{amb}	Operating ambient temperature range in free air		0	+70	°C

POWER MANAGEMENT

CONDITION	MAXIMUM 3.3 V SUPPLY CONSUMPTION MAXIMUM DISCRETE CAPACITANCE LOADS $V_{DDL} = 3.465$ V ALL STATIC INPUTS = V_{DD3} OR V_{SS}
Power-down mode (PWRDWN = 0)	60 mA
Full active 100/133 MHz	250 mA

CK00 (100/133 MHz) spread spectrum differential system clock generator

PCK2021

DC ELECTRICAL CHARACTERISTICS

T_{amb} = 0 to +70 °C

SYMBOL	PARAMETER	CONDITIONS			LIMITS			UNIT
		V _{DD} (V)	OTHER		MIN	TYP	MAX	
V _{IH}	HIGH level input voltage	3.135 to 3.465			2.0	—	V _{DD} +0.3	V
V _{IL}	LOW level input voltage	3.135 to 3.465			V _{SS} -0.3	—	0.8	V
V _{OH3}	3.3 V output HIGH voltage REF, 48M	3.135 to 3.465	I _{OH} = -1 mA		2.0	—	—	V
V _{OL3}	3.3 V output LOW voltage REF, 48M	3.135 to 3.465	I _{OH} = 1 mA		—	—	0.4	V
V _{OHP}	3.3 V output HIGH voltage 3V66/PCI	3.135 to 3.465	I _{OH} = -1 mA		2.4	—	—	V
V _{OLP}	3.3 V output LOW voltage 3V66/PCI	3.135 to 3.465	I _{OH} = 1 mA		—	—	0.55	V
I _{OH}	Output HIGH current 3V66/PCI	3.135	V _{OUT} = 1.0 V	Type 5 12 – 55 Ω	-33	—	—	mA
		3.465	V _{OUT} = 3.135 V		—	—	-33	mA
I _{OH}	Output HIGH current 48 MHz, REF	3.135	V _{OUT} = 1.0 V	Type 3 20 – 60 Ω	-29	—	—	mA
		3.465	V _{OUT} = 3.135 V		—	—	-23	mA
I _{OH}	Output HIGH current HOST/HOST_BAR	3.135 to 3.465	0.66 V	Type X1	11	—	—	mA
			0.76 V		—	—	12.7	mA
I _{OL}	Output LOW current 3V66/PCI	3.135	V _{OUT} = 1.95 V	Type 5 12 – 55 Ω	30	—	—	mA
		3.465	V _{OUT} = 0.4 V		—	—	38	mA
I _{OL}	Output LOW current 48 MHz, REF	3.135	V _{OUT} = 1.95 V	Type 3 20 – 60 Ω	29	—	—	mA
		3.465	V _{OUT} = 0.4 V		—	—	27	mA
V _{OL}	HOST/HOST_BAR	V _{SS} = 0 V	R _S = 33.2 Ω R _P = 49.9 Ω	Type X1	—	—	0.05	V
±I _I	Input leakage current	3.465	0 < V _{IN} < V _{DD3}		-50	—	50	μA
±I _I	Input leakage current – REF/SELC	3.465	0 < V _{IN} < V _{DD3}		-100	—	100	μA
±I _{OZ}	3-State output OFF-State current	3.465	V _{OUT} = V _{DD} or GND	I _O = 0	—	—	10	μA
C _{in}	Input pin capacitance				—	—	5	pF
C _{out}	Output pin capacitance				—	—	6	pF
C _{xtal}	Crystal input capacitance				13.5	—	22.5	pF

CK00 (100/133 MHz) spread spectrum differential system clock generator

PCK2021

AC ELECTRICAL CHARACTERISTICS

 $V_{DD3} = 3.3\text{ V} \pm 5\%$; $f_{\text{crystal}} = 14.31818\text{ MHz}$

Host clock outputs

 $T_{\text{amb}} = 0\text{ to }+70\text{ }^{\circ}\text{C}$; see Figure 1 for waveforms and Figure 6 for test setup.

SYMBOL	PARAMETER	LIMITS				UNITS	NOTES
		133 MHz MODE		100 MHz MODE			
		MIN	MAX	MIN	MAX		
t_{PERIOD}	HOST CLK average period	7.5	7.65	10.0	10.2	ns	11, 14, 20
Abs Min Period	Absolute minimum host clock period	7.35	N/A	9.85	N/A	ns	11, 14, 20
t_{RISE}	HOST CLK rise time	175	700	175	700	ns	11, 15, 20
t_{FALL}	HOST CLK fall time	175	700	175	700	ps	11, 15, 20
t_{JITTER}	HOST_CLK cycle-to-cycle jitter	—	150	—	150	ps	11, 12, 14, 20
DUTY CYCLE	Output duty cycle	45	55	45	55	%	11, 14, 20
t_{SKEW}	HOST CLK pin-to-pin skew	—	100	—	100	ps	11, 14, 20
Rise/Fall Matching	Rise and Fall time matching	—	20%	—	20%		11, 16, 20
$V_{\text{crossover}}$		45% V_{OH}	55% V_{OH}	45% V_{OH}	55% V_{OH}	V	11, 14, 20

REFER TO NOTES ON PAGE 10.

USB clock output, 48MHz

 $T_{\text{amb}} = 0\text{ to }+70\text{ }^{\circ}\text{C}$; lump capacitance test load = 20 pF

SYMBOL	PARAMETER	LIMITS		UNITS	NOTES
		48 MHz MODE			
		MIN	MAX		
f	Frequency, actual	48.000		MHz	4
f_{D}	Deviation from 48 MHz	-0	+167	ppm	4
t_{RISE}	3V48MHZCLK rise time	1.0	4.0	ns	8, 20
t_{FALL}	3V48MHZCLK fall time	1.0	4.0	ns	8, 20
t_{JITTER}	Cycle-to-cycle jitter	—	250	ps	18, 20
DUTY CYCLE	Output duty cycle	45	55	%	18, 20

REFER TO NOTES ON PAGE 10.

PCI Outputs

 $T_{\text{amb}} = 0\text{ to }+70\text{ }^{\circ}\text{C}$

SYMBOL	PARAMETER	LIMITS		UNITS	NOTES
		MIN	MAX		
t_{PERIOD}	Period	30.0	N/A	ns	2, 3, 9, 20
t_{HIGH}	High time	12.0	N/A	ns	5, 10, 20
t_{LOW}	Low time	12.0	N/A	ns	6, 10, 20
t_{RISE}	Rise time	0.5	2.0	ns	8, 20
t_{FALL}	Fall time	0.5	2.0	ns	18, 20
DUTY CYCLE	Duty cycle	45	55	%	18, 20
t_{JITTER}	Cycle-to-cycle jitter	—	150	ps	18, 20
t_{SKEW}	Pin-to-pin skew	—	150	ps	2

REFER TO NOTES ON PAGE 10.

CK00 (100/133 MHz) spread spectrum differential system clock generator

PCK2021

3V66 Outputs

T_{amb} = 0 to +70 °C

SYMBOL	PARAMETER	LIMITS		UNITS	NOTES
		MIN	MAX		
t _{PERIOD}	Period	15.0	16.0	ns	2, 3, 9, 20
t _{HIGH}	High time	5.25	N/A	ns	5, 10, 20
t _{LOW}	Low time	5.05	N/A	ns	6, 10, 20
t _{RISE}	Rise time	0.5	2.0	ns	8, 20
t _{FALL}	Fall time	0.5	2.0	ns	18, 20
DUTY CYCLE	Duty cycle	45	55	%	18, 20
t _{JITTER}	Cycle-to-cycle jitter	—	150	ps	18, 20

REFER TO NOTES ON PAGE 10.

REF clock output

T_{amb} = 0 to +70 °C; lump capacitance test load = 20 pF

SYMBOL	PARAMETER	LIMITS		UNITS	NOTES
		48 MHz MODE			
		MIN	MAX		
f	Frequency, actual	14.318		MHz	17, 20
t _{JITTER}	Cycle-to-cycle jitter	—	300	ps	18, 20
DUTY CYCLE	Output duty cycle	45	55	%	18, 20

REFER TO NOTES ON PAGE 10.

All outputs

T_{amb} = 0 to +70 °C

SYMBOL	PARAMETER	LIMITS				UNITS	NOTES
		133 MHz MODE		100 MHz MODE			
		MIN	MAX	MIN	MAX		
t _{PZL} , t _{PZH}	Output enable delay (all outputs)	1.0	10.0	1.0	10.0	ns	20
t _{PZL} , t _{PZH}	Output disable delay (all outputs)	1.0	10.0	1.0	10.0	ns	20
t _{STABLE}	All clock stabilization from power-up	—	3	—	3	ms	7, 20

REFER TO NOTES ON PAGE 10.

CK00 (100/133 MHz) spread spectrum differential system clock generator

PCK2021

Group offset limits

GROUP	OFFSET	MEASUREMENT LOADS (LUMPED)	MEASUREMENT POINTS	NOTES
3V66 to PCI	0–250 ps, 3V66 leads	30 pF	1.5 V	19, 20

NOTES TO THE AC TABLES:

- Output drivers must have monotonic rise/fall times through the specified V_{OL}/V_{OH} levels.
- Period, jitter, offset, and skew measured on rising edge at 1.5 V for 3.3 V clocks.
- PCI is a fixed 33 MHz and 3V66 is a fixed 66 MHz.
- Frequency accuracy of 48 MHz must be +167 ppm to match USB default.
- t_{HIGH} is measured at 2.4 V for 3.3 V outputs, as shown in Figure 7.
- t_{LOW} is measured at 0.4 V for all outputs as shown in Figure 7.
- the time is specified from when V_{DDQ} achieves its normal operating level (typical condition $V_{DDQ} = 3.3$ V) until the frequency output is stable and operating within specification.
- t_{RISE} and t_{FALL} are measured as a transition through the threshold region $V_{OL} = 0.4$ V and $V_{OH} = 2.4$ V (1 mA) JEDEC specification.
- The average period over any 1 μ s period of time must be greater than the minimum specified period.
- Calculated at minimum edge rate (1 V/ns) to guarantee 45–55% duty cycle. Pulse width is required to be wider at faster edge rate to ensure duty specification is met.
- Test load is $R_S = 33.2 \Omega$, $R_P = 49.9 \Omega$.
- Must be guaranteed in a realistic system environment.
- Configured for $V_{OH} = 0.71$ V in a 50 Ω environment.
- Measured at crossing points.
- Measured at 20% to 80%.
- Determined as a fraction of $2 \cdot (t_{RP} - t_{RN}) / (t_{RP} + t_{RN})$, where t_{RP} is a rising edge, and t_{RN} is an intersecting falling edge.
- Frequency generated by crystal oscillator
- Voltage measure point ($V_M = 1.5$ V).
- All offsets are to be measured at rising edges.
- Parameters are guaranteed by design.

CK00 (100/133 MHz) spread spectrum differential system clock generator

PCK2021

AC WAVEFORMS

$V_M = 1.25\text{ V @ }V_{DDL}$ and $1.5\text{ V @ }V_{DD3}$

$V_X = V_{OL} + 0.3\text{ V}$

$V_Y = V_{OH} - 0.3\text{ V}$

V_{OL} and V_{OH} are the typical output voltage drop that occur with the output load.

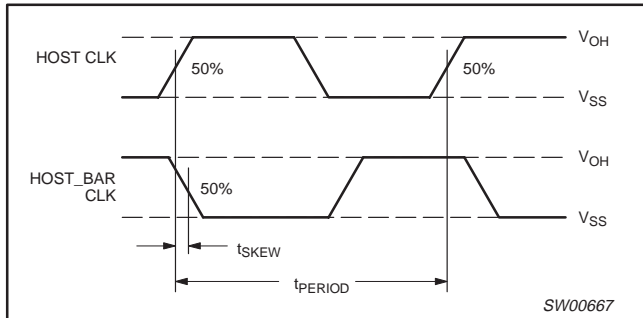

Figure 1. HOST CLOCK

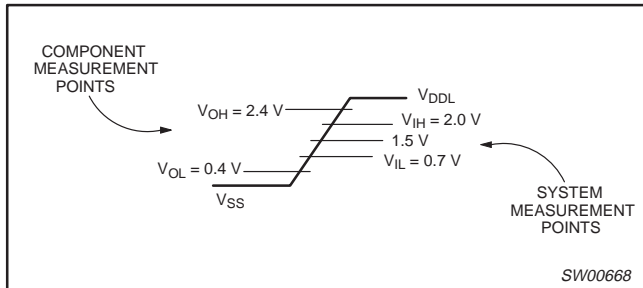

Figure 2. 3.3 V clock waveforms

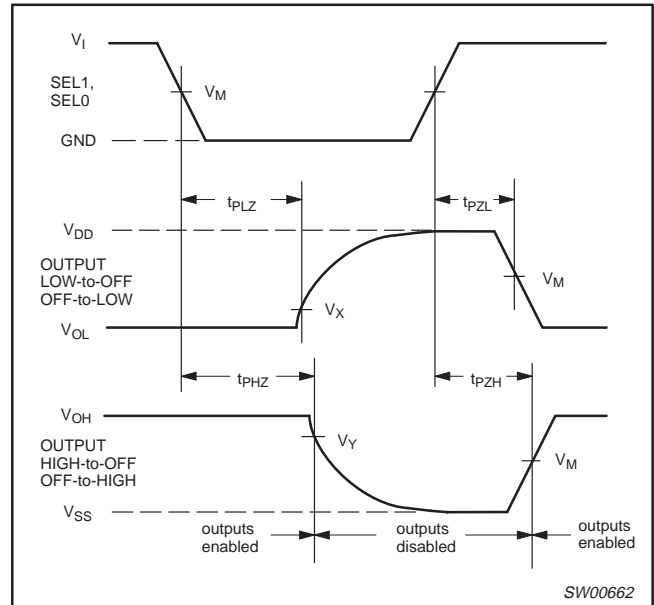

Figure 3. State enable and disable times

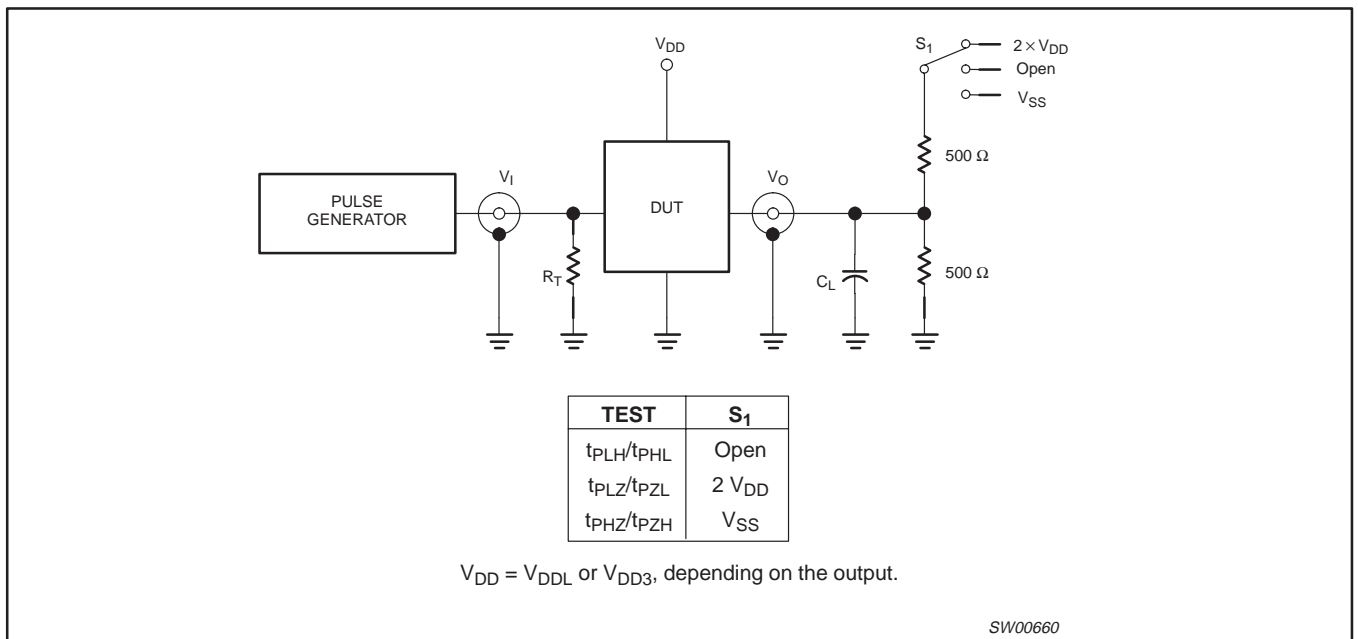
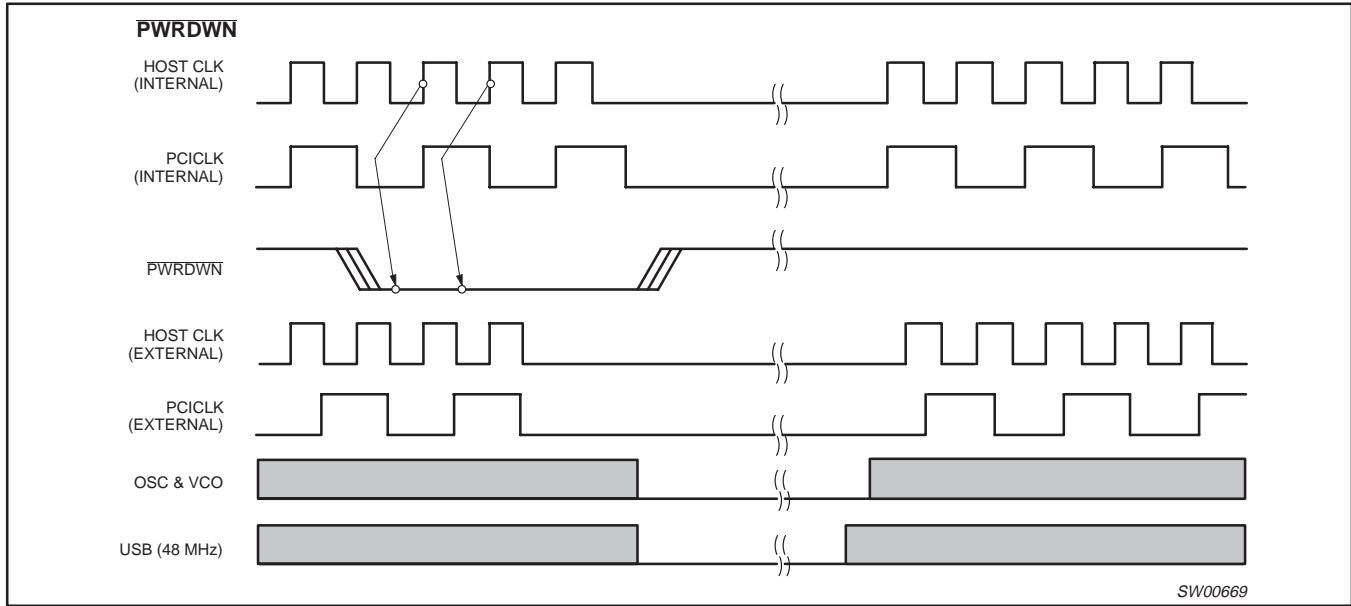

Figure 4. Load circuitry for switching times

CK00 (100/133 MHz) spread spectrum differential system clock generator

PCK2021



SW00669

Figure 5. Power management

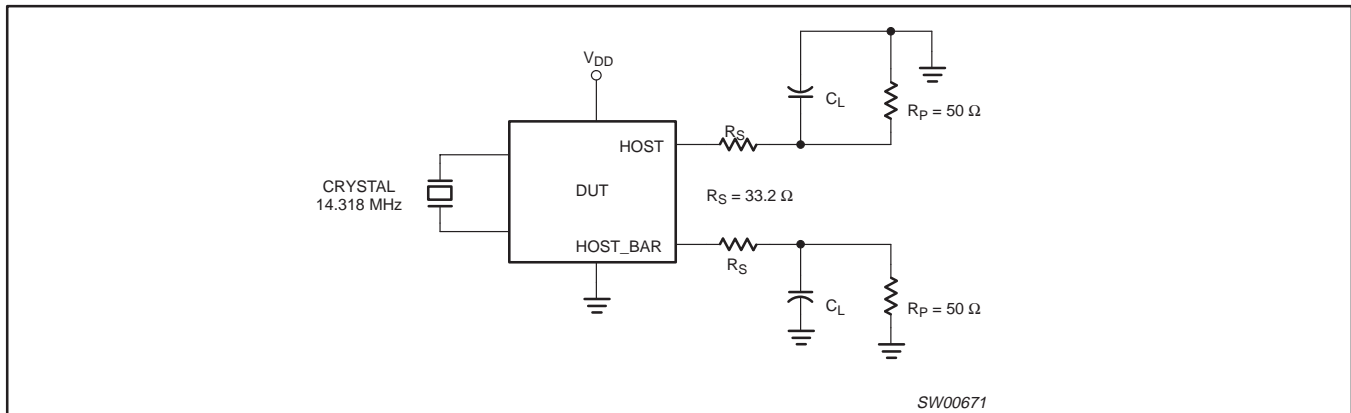

SW00671

Figure 6. HOST CLOCK measurements

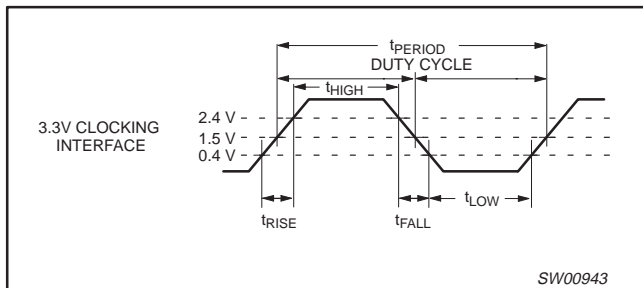

SW00943

Figure 7. 3.3 V clock waveforms

CK00 (100/133 MHz) spread spectrum differential system clock generator

PCK2021

TSSOP48: plastic thin shrink small outline package; 48 leads; body width 6.1 mm

SOT362-1

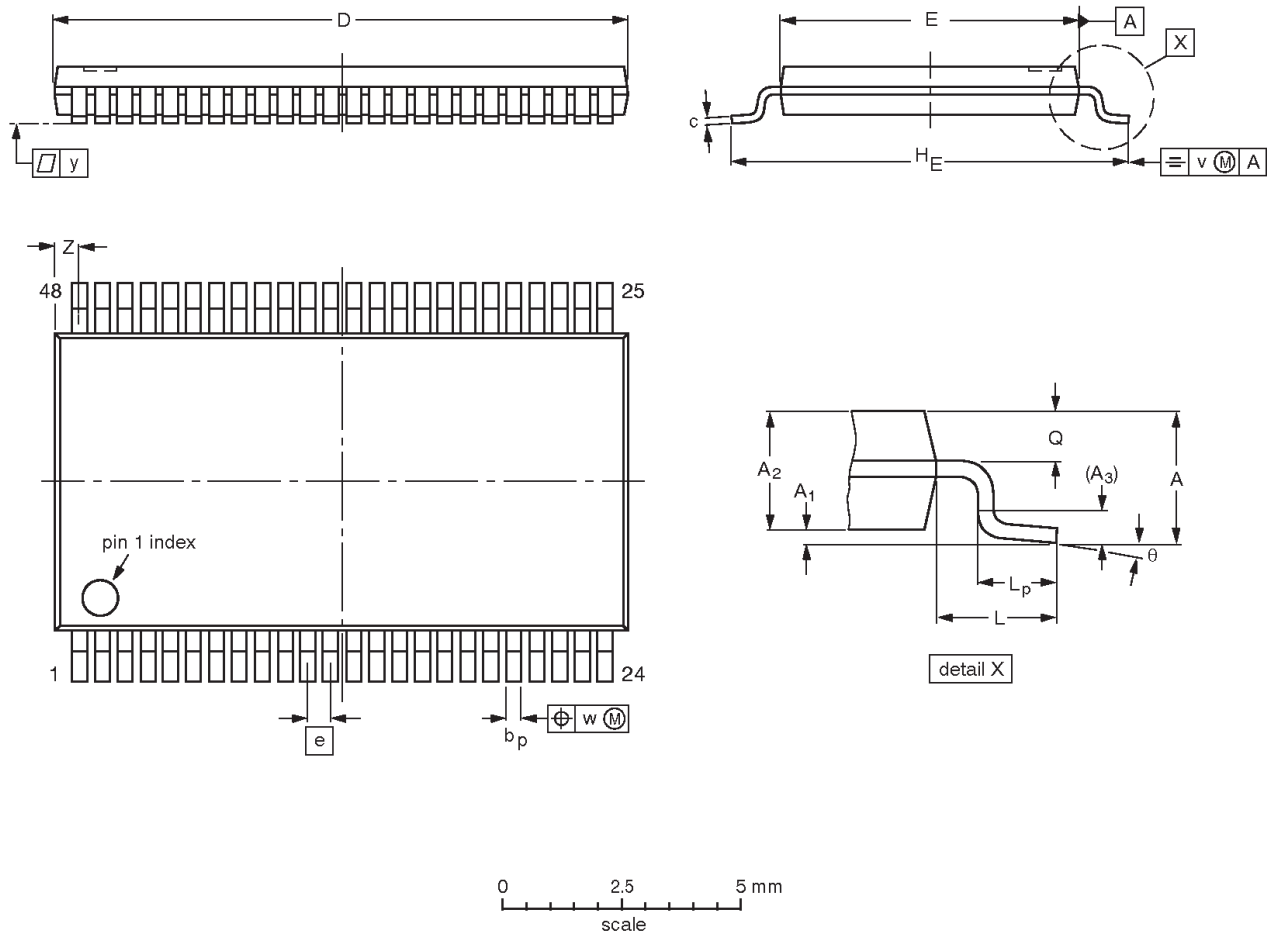

DIMENSIONS (mm are the original dimensions).

UNIT	A max.	A ₁	A ₂	A ₃	b _p	c	D ⁽¹⁾	E ⁽²⁾	e	H _E	L	L _p	Q	v	w	y	Z	θ
mm	1.2	0.15 0.05	1.05 0.85	0.25	0.28 0.17	0.2 0.1	12.6 12.4	6.2 6.0	0.5	8.3 7.9	1	0.8 0.4	0.50 0.35	0.25	0.08	0.1	0.8 0.4	8° 0°

Notes

1. Plastic or metal protrusions of 0.15 mm maximum per side are not included.
2. Plastic interlead protrusions of 0.25 mm maximum per side are not included.

OUTLINE VERSION	REFERENCES				EUROPEAN PROJECTION	ISSUE DATE
	IEC	JEDEC	EIAJ			
SOT362-1		MO-153				-95-02-10 99-12-27

CK00 (100/133 MHz) spread spectrum differential system clock generator

PCK2021

SSOP48: plastic shrink small outline package; 48 leads; body width 7.5 mm

SOT370-1

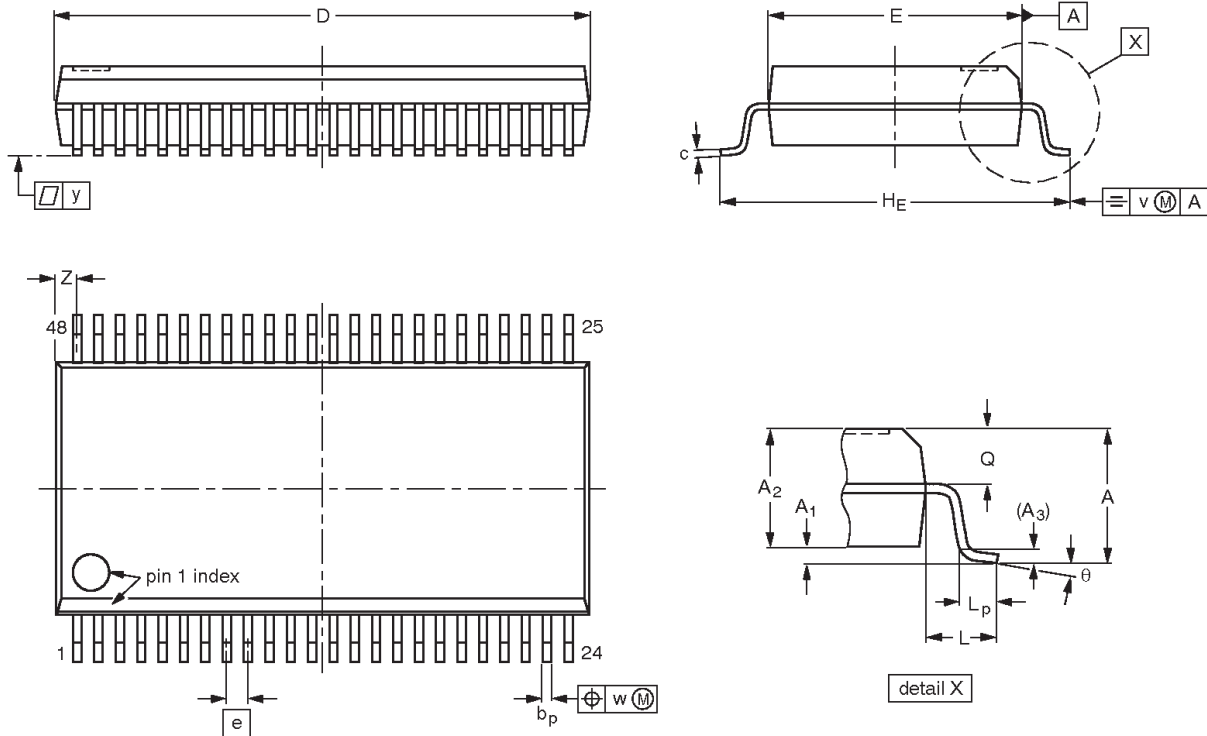

DIMENSIONS (mm are the original dimensions)

UNIT	A max.	A ₁	A ₂	A ₃	b _p	c	D ⁽¹⁾	E ⁽¹⁾	e	H _E	L	L _p	Q	v	w	y	Z ⁽¹⁾	θ
mm	2.8	0.4 0.2	2.35 2.20	0.25	0.3 0.2	0.22 0.13	16.00 15.75	7.6 7.4	0.635	10.4 10.1	1.4	1.0 0.6	1.2 1.0	0.25	0.18	0.1	0.85 0.40	8° 0°

Note

1. Plastic or metal protrusions of 0.25 mm maximum per side are not included.

OUTLINE VERSION	REFERENCES				EUROPEAN PROJECTION	ISSUE DATE
	IEC	JEDEC	EIAJ			
SOT370-1		MO-118				95-02-04 99-12-27

CK00 (100/133 MHz) spread spectrum differential
system clock generator

PCK2021

NOTES

CK00 (100/133 MHz) spread spectrum differential system clock generator

PCK2021

Data sheet status

Data sheet status ^[1]	Product status ^[2]	Definitions
Objective data	Development	This data sheet contains data from the objective specification for product development. Philips Semiconductors reserves the right to change the specification in any manner without notice.
Preliminary data	Qualification	This data sheet contains data from the preliminary specification. Supplementary data will be published at a later date. Philips Semiconductors reserves the right to change the specification without notice, in order to improve the design and supply the best possible product.
Product data	Production	This data sheet contains data from the product specification. Philips Semiconductors reserves the right to make changes at any time in order to improve the design, manufacturing and supply. Changes will be communicated according to the Customer Product/Process Change Notification (CPCN) procedure SNW-SQ-650A.

[1] Please consult the most recently issued datasheet before initiating or completing a design.

[2] The product status of the device(s) described in this data sheet may have changed since this data sheet was published. The latest information is available on the Internet at URL <http://www.semiconductors.philips.com>.

Definitions

Short-form specification — The data in a short-form specification is extracted from a full data sheet with the same type number and title. For detailed information see the relevant data sheet or data handbook.

Limiting values definition — Limiting values given are in accordance with the Absolute Maximum Rating System (IEC 134). Stress above one or more of the limiting values may cause permanent damage to the device. These are stress ratings only and operation of the device at these or at any other conditions above those given in the Characteristics sections of the specification is not implied. Exposure to limiting values for extended periods may affect device reliability.

Application information — Applications that are described herein for any of these products are for illustrative purposes only. Philips Semiconductors make no representation or warranty that such applications will be suitable for the specified use without further testing or modification.

Disclaimers

Life support — These products are not designed for use in life support appliances, devices or systems where malfunction of these products can reasonably be expected to result in personal injury. Philips Semiconductors customers using or selling these products for use in such applications do so at their own risk and agree to fully indemnify Philips Semiconductors for any damages resulting from such application.

Right to make changes — Philips Semiconductors reserves the right to make changes, without notice, in the products, including circuits, standard cells, and/or software, described or contained herein in order to improve design and/or performance. Philips Semiconductors assumes no responsibility or liability for the use of any of these products, conveys no license or title under any patent, copyright, or mask work right to these products, and makes no representations or warranties that these products are free from patent, copyright, or mask work right infringement, unless otherwise specified.

Philips Semiconductors
811 East Arques Avenue
P.O. Box 3409
Sunnyvale, California 94088-3409
Telephone 800-234-7381

© Copyright Philips Electronics North America Corporation 2001
All rights reserved. Printed in U.S.A.

Date of release: 07-01

Document order number:

Let's make things better.

